

FABRICATED "Y" TYPE STRAINER

Model: FY 150/300/600/900/1500/2500

ANSI CL.: 150/300/600/900/1500/2500LB

Unit:mm

Nom,Size		d	L	I	W	Element	
A	B					D1	I1
25	1	34.0	270	195	1/2	24	191
40	1-1/2	48.6	280	235	1/2	34	231
50	2	60.5	290	240	1/2	37	236
65	2-1/2	76.3	320	250	1/2	52	245
80	3	89.1	320	310	3/4	60	305
90	3-1/2	101.6	360	330	3/4	70	325
100	4	114.3	400	350	3/4	80	345
125	5	139.8	450	400	3/4	110	391
150	6	165.2	480	440	3/4	120	430
200	8	216.3	580	525	3/4	170	512
250	10	267.4	680	630	3/4	220	617
300	12	318.5	800	730	3/4	250	717
350	14	355.6	930	850	3/4	300	834
400	16	406.4	1000	890	3/4	340	877
450	18	457.2	1080	950	3/4	400	938
500	20	508.0	1140	1020	3/4	450	1009
600	24	609.6	1320	1224	3/4	540	1214

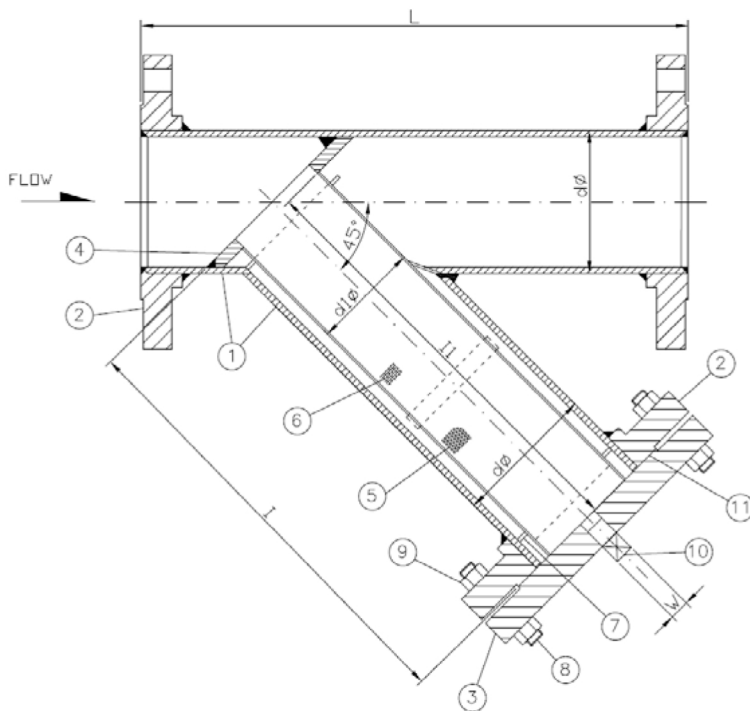

Thickness of the materials varies depending on the designed pressure, temperature and corrosion allowance applicable. SCH. 160,80,40.

NO.	PARTS	MATERIALS
1	BODY PIPE	A106,A53Gr.B or A312TP304
2	FLANGE	A105/F304
3	COVER	A105/F305
4	ELEMENT SEAT	304 S.S.
5	HOLDER OF SCREEN	304 S.S.
6	SCREEN	304 S.S.
7	STOPPER	304 S.S.
8	BOLTS	A193-B7
9	NUTS	A194-2H
10	PLUG	A105/F304
11	GASKET	SPW+304S.S.

MESH SIZE:20,40,60

TEST PRESSURE

Shell	150#	235psi	600#	1235psi
	300#	615psi	900#	1850psi
			1500#	3085psi



Exclusive distributor

ph: (+61 3) 9764 1149

web: www.razvalve.com

